

OPTIONS FOR ABB DRIVES AND CONVERTERS

# Absolute Encoder Interface FEN-11

## User's manual

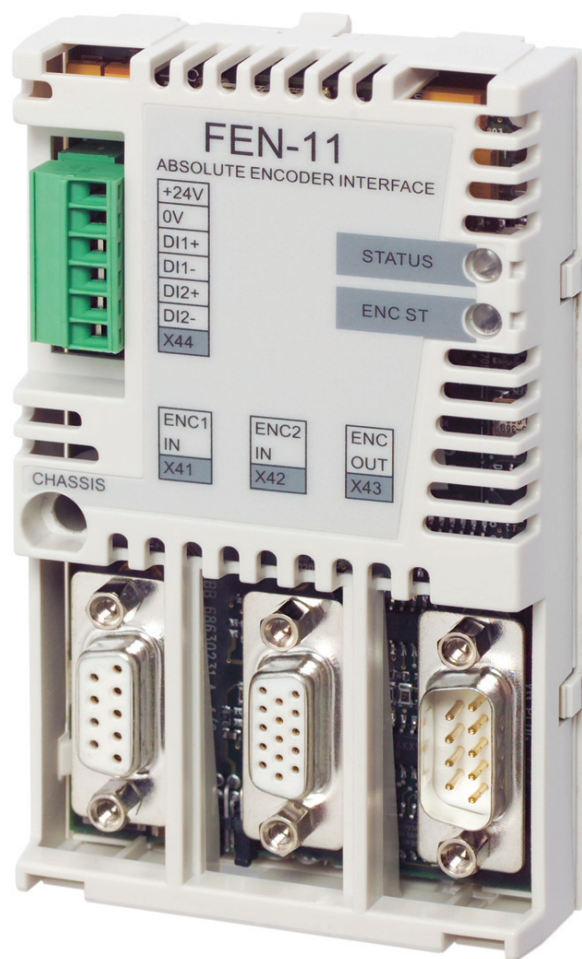



# Absolute Encoder Interface FEN-11

User's manual

Table of contents



3AFE68784841 Rev D  
EN  
Original instructions  
EFFECTIVE: 2023-07-14



# Table of contents

---

## 1 Safety instructions

Contents of this chapter .....	7
Overview .....	7
General safety instructions .....	7

## 2 Introduction

Contents of this chapter .....	9
Intended audience .....	9
Before you start .....	9

## 3 Hardware description

Contents of this chapter .....	11
The FEN-11 Absolute Encoder Interface .....	12
FEN-11 connections .....	13
Isolation areas .....	14
Compatibility .....	15
Absolute Encoders .....	15
TTL Encoders .....	15

## 4 Installation

Contents of this chapter .....	17
Setting the supply voltage .....	18
Mounting .....	19
Terminal designations .....	20
Abbreviations .....	20
TTL encoder input (X41) .....	20
Absolute encoder input (X42) .....	21
General pin order .....	21
Pin order with enDat absolute encoder .....	21
Pin order with HIPERFACE absolute encoders .....	22
Pin order with sin/cos encoders with/without sin/cos commutation signals and reference mark .....	22
Pin order with SSI absolute encoders .....	23
Pin order with Tamagawa absolute encoders .....	23
TTL encoder emulation output (X43) .....	24
Digital inputs for position latching (X44) .....	25
General encoder wiring guidelines .....	25
TTL encoder input (X41) .....	26
Absolute encoder input (X42) .....	27
TTL encoder emulation output (X43) .....	30
Digital inputs for position latching (X44) .....	31
General encoder phasing principle .....	31
EnDat and SSI serial link .....	32
HIPERFACE serial link .....	33

---



6 Table of contents

Encoder commutation signals ..... 34  
Reference mark ..... 34

**5 Start-up**

Contents of this chapter ..... 35  
Programming ..... 35

**6 Fault tracing**

Contents of this chapter ..... 37  
Diagnostic LEDs ..... 37

**7 Technical data**

Contents of this chapter ..... 39  
Dimensions ..... 40  
General ..... 40  
Connectors: ..... 41  
TTL encoder input (X41) ..... 41  
Absolute encoder input (X42) ..... 41  
TTL encoder emulation output (X43) ..... 42  
Digital inputs for position latch (X44) ..... 42

**Further information**



# 1

## Safety instructions

---

### Contents of this chapter

The chapter contains the warning symbols and the safety instructions which you must obey when you install or connect an optional module to a drive or converter. If you ignore the safety instructions, injury, death or damage can occur. Read this chapter before you start the installation.

### Overview

This chapter states the general safety instructions that must be followed when installing and operating the FEN-11.

In addition to the safety instructions given below, read the complete safety instructions of the specific drive you are working on.

These warnings are intended for all who work on the drive. Ignoring the instructions can cause physical injury or death, or damage the equipment.

### General safety instructions

---

**WARNING!**

All electrical installation and maintenance work on the drive must be carried out by qualified electricians only.

---

The drive and adjoining equipment must be properly earthed.

Do not attempt any work on a powered drive. After switching off the mains, always allow the intermediate circuit capacitors 5 minutes to discharge before working on the frequency converter, the motor or the motor cable. Check (with a voltage tester) that the drive is in fact discharged before beginning work.

---

## 8 Safety instructions

The motor cable terminals of the drive are at a dangerously high voltage when mains power is applied, regardless of motor operation.

There can be dangerous voltages inside the drive from external control circuits even when the drive mains power is shut off.

Exercise appropriate care when working on the unit.

These warnings are intended for all who work on the drive. Ignoring the instructions can cause physical injury or death, or damage the equipment.

For complete safety instructions see the drive manuals.

---



2

# Introduction

---

## Contents of this chapter

This chapter introduces this manual.

## Intended audience

The manual is intended for the people who are responsible for commissioning and using the FEN-11. The reader is expected to have a basic knowledge of electrical fundamentals, electrical wiring practices and how to operate the drive.

## Before you start

It is assumed that the drive is installed and the drive power supply is switched off before starting the installation of the extension module. Ensure that all dangerous voltages connected from external control circuits to the inputs and outputs of the drive are switched off.

In addition to conventional installation tools, have the drive manuals available during the installation as they contain important information not included in this manual. The drive manuals are referred to at various points of this document.

---





# 3

## Hardware description

---

### Contents of this chapter

This chapter contains a short description of the FEN-11 Absolute Encoder Interface.

---

## The FEN-11 Absolute Encoder Interface

The FEN-11 offers an interface for an absolute encoder with PTC/Pt1000/KTY support and TTL encoder connection and a TTL encoder emulation output. It also supports two digital inputs for position latching.

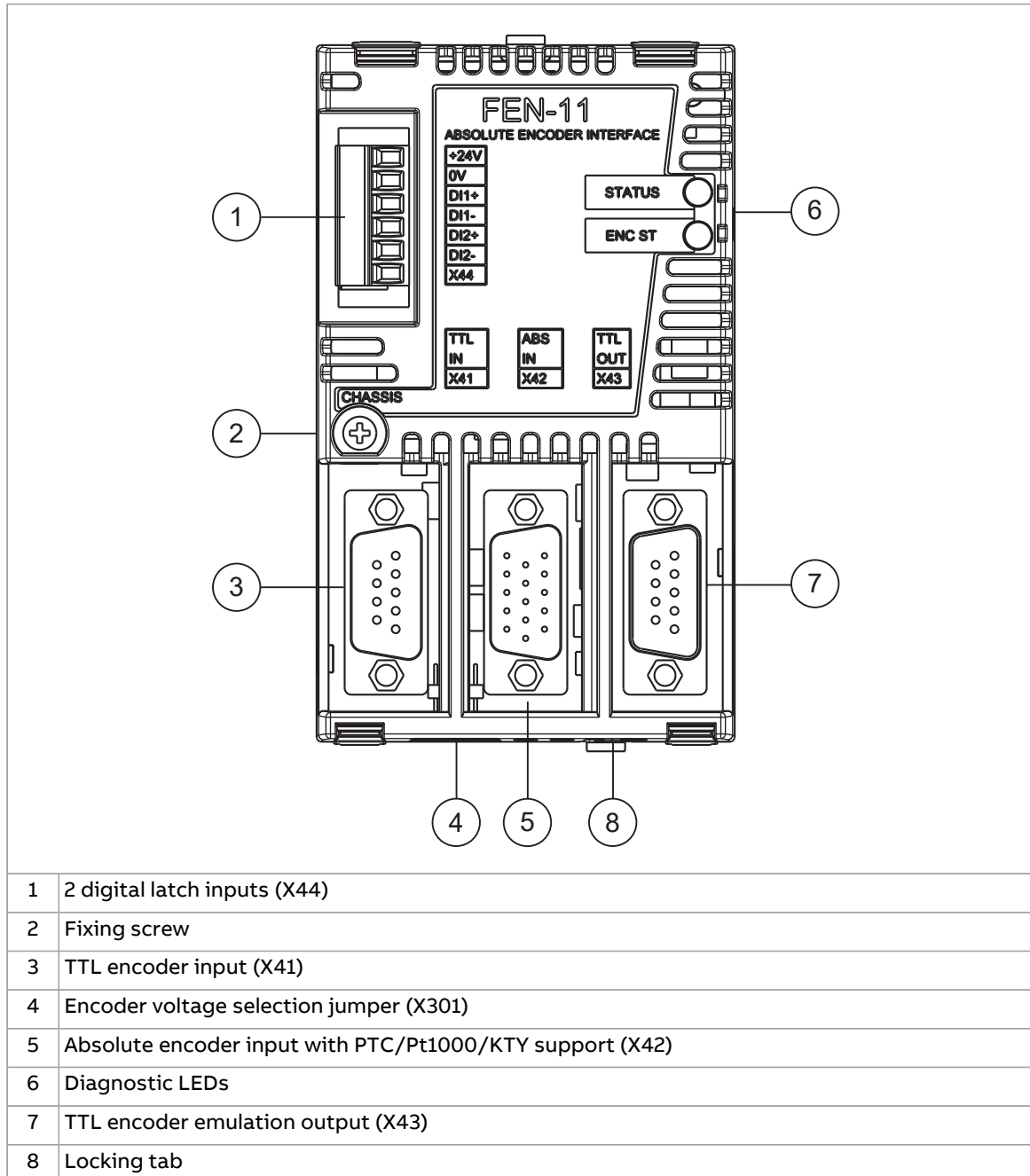

■ **FEN-11 connections**

The following figure shows an overview of the connections of the FEN-11.

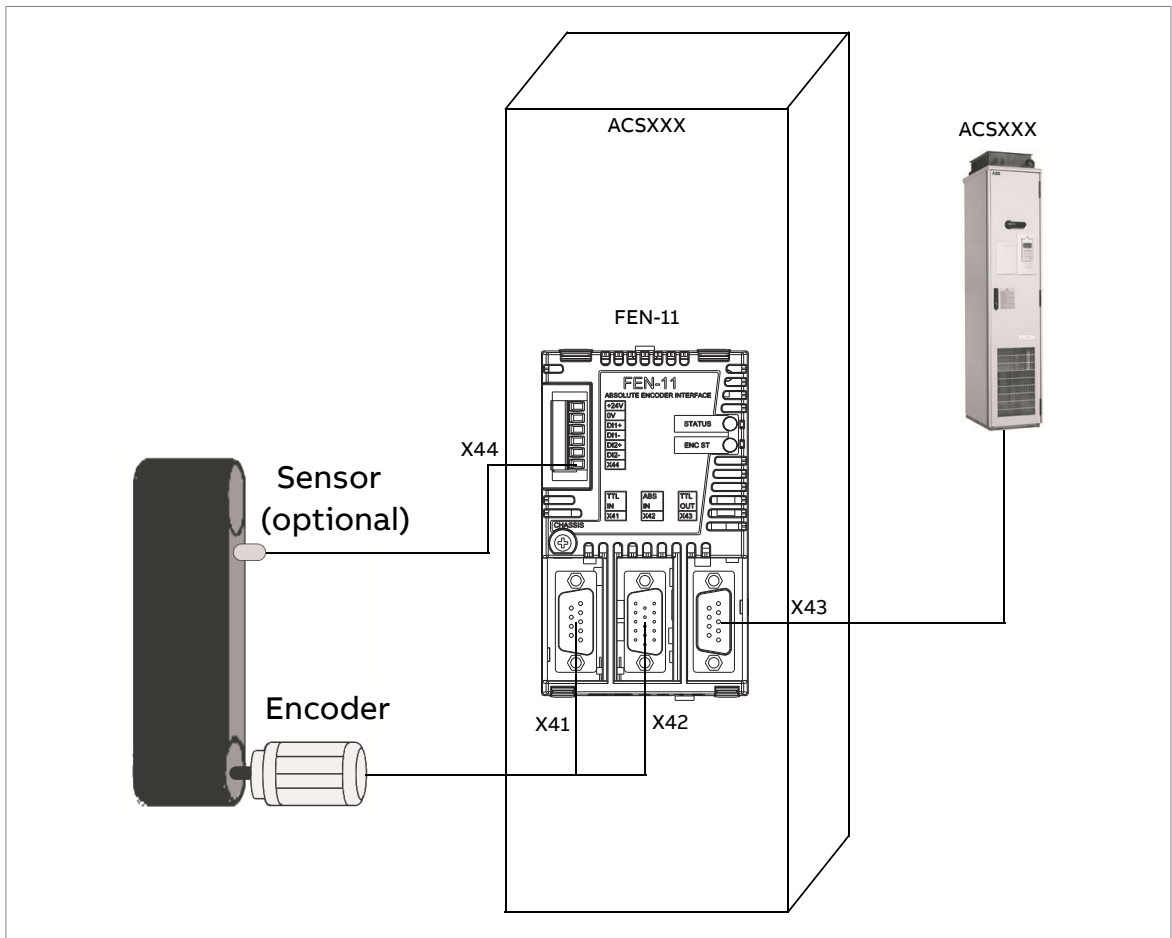

■ **Isolation areas**

The following figure describes the different isolation areas of the module.

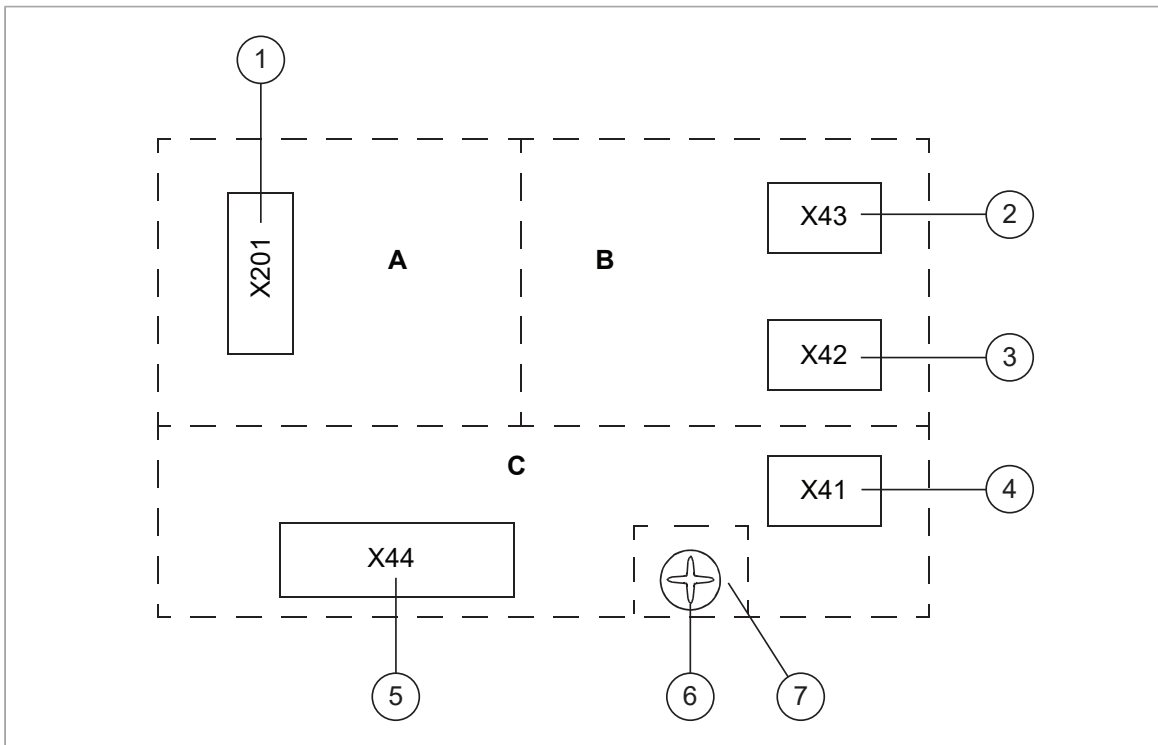

1	Connection to the drive
2	TTL encoder emulation output
3	Absolute encoder input
4	TTL encoder input
5	Digital latches
6	Fixing screw
7	Chassis

The shields of sockets X41 and X42 and plug X43 are connected to chassis. The fixing screw connects the chassis to ground.

## Compatibility

FEN-11 is compatible with the following encoders.

### ■ Absolute Encoders

- Sin/cos incremental encoder, 1...65535 periods/rev, also supports reference mark and sin/cos commutation signals
- Endat 2.1 and 2.2 with and without sin/cos signals
- HIPERFACE
- SSI, with and without sin/cos signals
- Tamagawa, 17/33-bit Smart Abs and 17-bit Smart Inc.

### ■ TTL Encoders

- TTL incremental encoder, 1...65535 periods/rev, supports reference mark (zero pulse).
-





# 4

## Installation

---

### Contents of this chapter

This chapter contains instructions on installing the Absolute Encoder Interface module.

---



**WARNING!**

Follow the safety instructions given in this guide and in the drive's hardware manual.

---

## Setting the supply voltage

**WARNING!**

Selecting the wrong supply voltage may damage or break the encoder.

A selectable supply voltage is provided for the absolute encoder's and the TTL encoder's input. A +5.5 V or a +24 V voltage for a TTL encoder and a +5.5 V or a +8 V voltage for an absolute encoder can be selected by vertically mounted jumpers as described by the following figure.

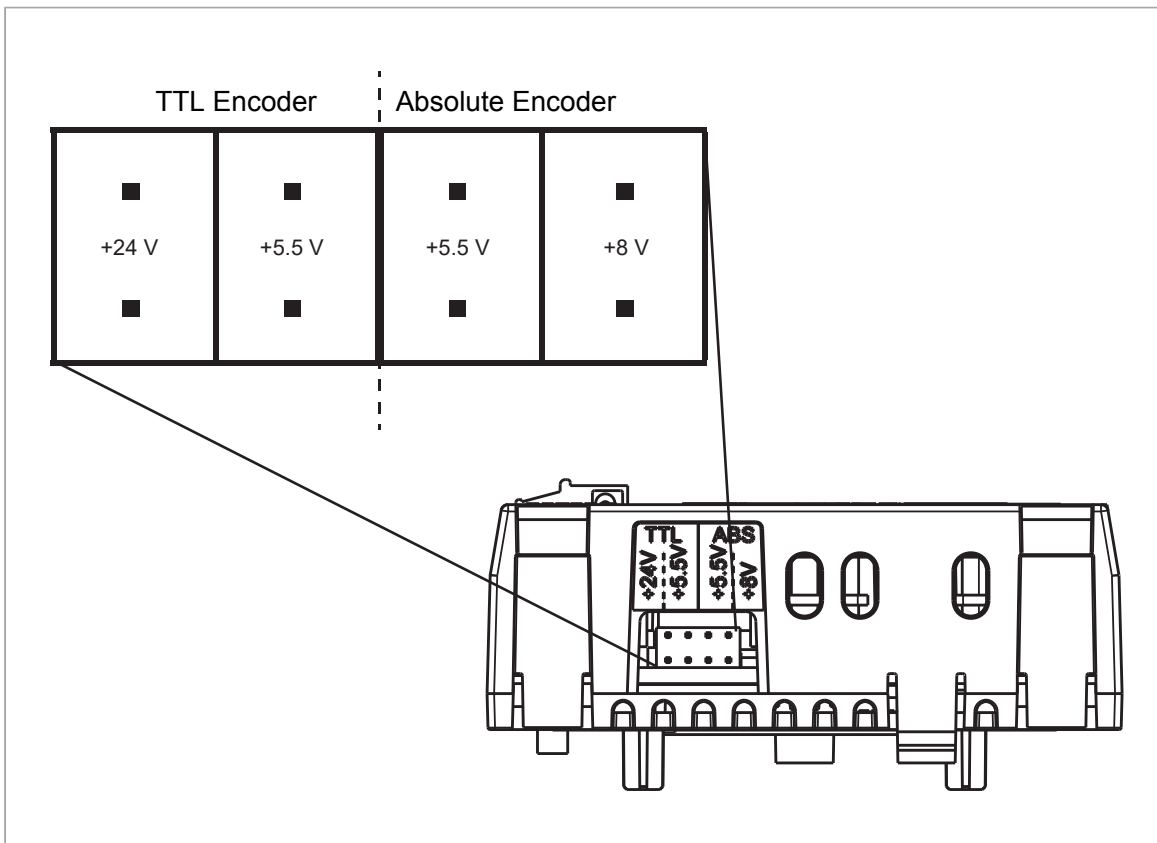

**Note:** If an external power supply is used, the appropriate jumper must be removed.

**Note:** If another FEN interface's TTL emulation output is connected to TTL input, the appropriate jumper must be removed.

## Mounting

---

**WARNING!**

Before installation, do the electrical safety precautions given in section [Safety instructions](#).

---

**Note:** Before mounting the option module, set the supply voltage jumpers as described above.

The option module is to be inserted into the option slot of the drive. See the drive hardware manual for more information.

The module is held in place with plastic retaining clips, a locking tab and one screw. The screw also provides the earthing of the cable shields connected to the module and interconnects the GND signals of the module and the drive.

On installation of the module, the signal and power connection to the drive is automatically made through a 20-pin connector.

Numbers in brackets refer to the layout drawing in section layout.

Mounting procedure:

1. Pull out the locking tab (8)
2. Insert the module carefully into the option slot until the retaining clips lock the module into position
3. Push in the locking tab (8)
4. Fasten the screw (included) to the stand-off.

If you need to remove the adapter module after it has been installed into the drive, use a suitable tool (e.g. small pliers) to carefully pull out the locking tab.

**Note:** Correct installation of the screw is essential for fulfilling the EMC requirements and for proper operation of the module.

---

## Terminal designations

### ■ Abbreviations

AI	Analog input
DI	Digital input
DIO	Digital input and output
DO	Digital output
PO	Power output

### ■ TTL encoder input (X41)

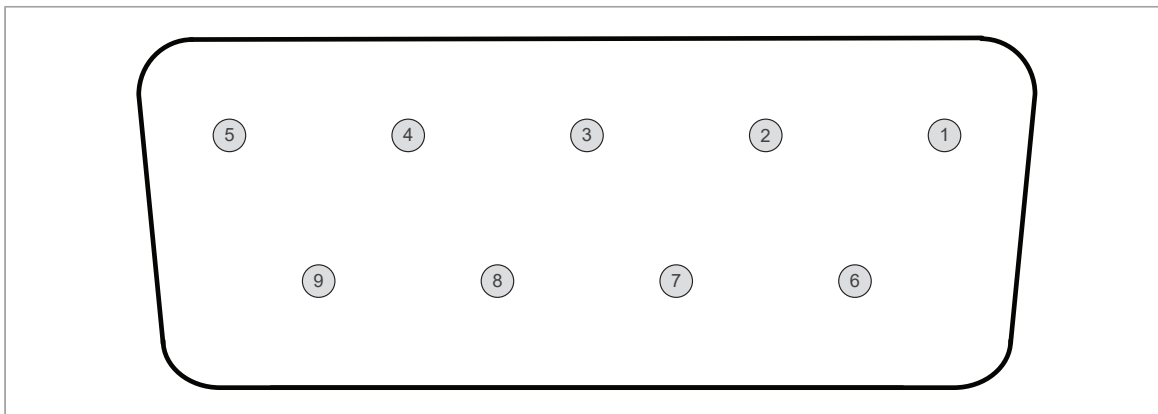

Pin	Name	Direction	Description
1	A+	DI	Channel A+
2	B+	DI	Channel B+
3	Z+	DI	Channel Z+
4	COM_C	-	Common
5	VCC_ENC_1	PO	Supply voltage (5.5 V or 24 V)
6	A-	DI	Channel A-
7	B-	DI	Channel B-
8	Z-	DI	Channel Z-
9	COM_C	-	Common
-	Shield	-	Shield

## ■ Absolute encoder input (X42)

### General pin order

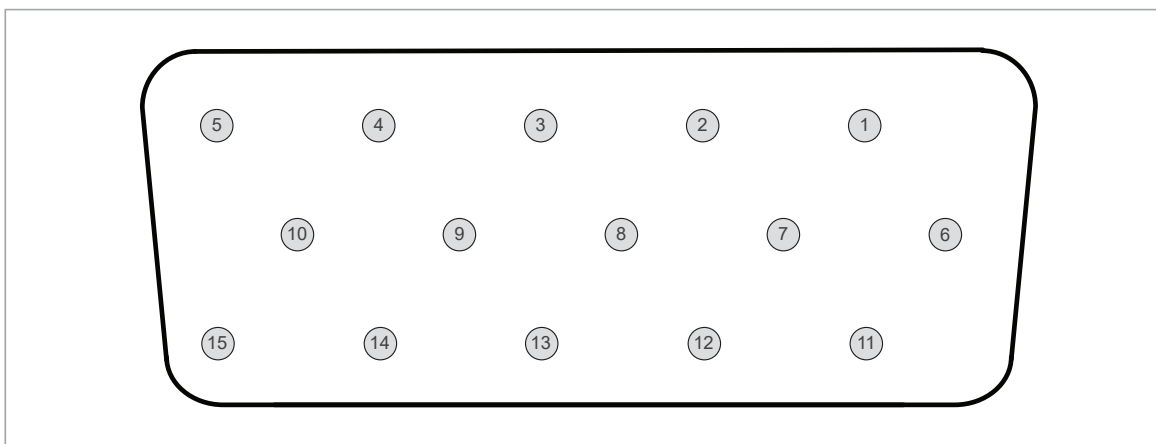

Pin	Name	Optional Function	Direction	Description
1	A-		AI	Sine ref.
2	B-		AI	Cosine ref.
3	PTC/Pt1000/KTY		AI	Temperature sensor
4	PTC/Pt1000/KTY_0V		AI	Common, 0V, reserved for temperature sensor
5	CLOCK	SIN_CM+	DO/AI	Clock or sine commutation signal
6	A+		AI	Sine signal
7	B+		AI	Cosine signal
8	COM_B		-	Common, 0V
9	NC <sup>1)</sup>	COS_CM+	AI	Cosine commutation signal
10	\CLOCK	SIN_CM-	DO/AI	Inverted clock or sine commutation signal, inverted
11	VCC_ENC_2		PO	Supply voltage (5.5 V or 8 V)
12	COM_B		-	Common, 0V
13	NC <sup>1)</sup>	COS_CM-	AI	Cosine commutation signal, inverted
14	DATA	Z+	DIO/DI	Data line or reference mark
15	\DATA	Z-	DIO/DI	Inverted data line, or reference mark, inverted
-	Shield		-	Shield

<sup>1)</sup> NC = Not connected

### Pin order with enDat absolute encoder

Pin	Name	Direction	Description
1	A-	AI	Sine ref.
2	B-	AI	Cosine ref.
3	PTC/Pt1000/KTY	AI	Temperature sensor
4	PTC/Pt1000/KTY_0V	AI	Common, 0V, reserved for temperature sensor
5	CLOCK	DO/AI	Clock
6	A+	AI	Sine signal
7	B+	AI	Cosine signal

## 22 Installation

8	COM_B	-	Common, 0V
9	NC <sup>1)</sup>	AI	Cosine commutation signal
10	\CLOCK	DO/AI	Inverted clock, inverted
11	VCC_ENC_2	PO	Supply voltage (5.5 V or 8 V)
12	COM_B	-	Common, 0V
13	NC <sup>1)</sup>	AI	Cosine commutation signal, inverted
14	DATA	DIO/DI	Data line or reference mark
15	\DATA	DIO/DI	Inverted data line, or reference mark, inverted
-	Shield	-	Shield

<sup>1)</sup> NC = Not connected

### Pin order with HIPERFACE absolute encoders

Pin	Name	Direction	Description
1	SIN-	AI	Sine ref.
2	COS-	AI	Cosine ref.
3	PTC/Pt1000/KTY	AI	Temperature sensor
4	PTC/Pt1000/KTY_0V	AI	Common, 0V, reserved for temperature sensor
5	NC <sup>1)</sup>	DO/AI	Clock or sine commutation signal
6	SIN+	AI	Sine signal
7	COS+	AI	Cosine signal
8	COM_B	-	Common, 0V
9	NC <sup>1)</sup>	AI	Cosine commutation signal
10	NC <sup>1)</sup>	DO/AI	Inverted clock or sine commutation signal, inverted
11	VCC_ENC_2	PO	Supply voltage (5.5 V or 8 V)
12	COM_B	-	Common, 0V
13	NC <sup>1)</sup>	AI	Cosine commutation signal, inverted
14	DATA	DIO/DI	Data line or reference mark
15	\DATA	DIO/DI	Inverted data line, or reference mark, inverted
-	Shield	-	Shield

<sup>1)</sup> NC = Not connected

### Pin order with sin/cos encoders with/without sin/cos commutation signals and reference mark

Pin	Name	Direction	Description
1	SIN-	AI	Sine ref.
2	COS-	AI	Cosine ref.
3	PTC/Pt1000/KTY	AI	Temperature sensor
4	PTC/Pt1000/KTY_0V	AI	Common, 0V, reserved for temperature sensor
5	SIN_CM+	DO/AI	Clock or sine commutation signal
6	SIN+	AI	Sine signal
7	COS+	AI	Cosine signal

8	COM_B	-	Common, 0V
9	COS_CM+	AI	Cosine commutation signal
10	SIN_CM-	DO/AI	Inverted clock or sine commutation signal, inverted
11	VCC_ENC_2	PO	Supply voltage (5.5 V or 8 V)
12	COM_B	-	Common, 0V
13	COS_CM-	AI	Cosine commutation signal, inverted
14	DATA	DIO/DI	Data line or reference mark
15	\DATA	DIO/DI	Inverted data line, or reference mark, inverted
-	Shield	-	Shield

### Pin order with SSI absolute encoders

Pin	Name	Direction	Description
1	SIN-	AI	Sine ref.
2	COS-	AI	Cosine ref.
3	PTC/Pt1000/KTY	AI	Temperature sensor
4	PTC/Pt1000/KTY_0V	AI	Common, 0V, reserved for temperature sensor
5	CLOCK	DO/AI	Clock or sine commutation signal
6	SIN+	AI	Sine signal
7	COS+	AI	Cosine signal
8	COM_B	-	Common, 0V
9	NC <sup>1)</sup>	AI	Cosine commutation signal
10	\CLOCK	DO/AI	Inverted clock or sine commutation signal, inverted
11	VCC_ENC_2	PO	Supply voltage (5.5 V or 8 V)
12	COM_B	-	Common, 0V
13	NC <sup>1)</sup>	AI	Cosine commutation signal, inverted
14	DATA	DIO/DI	Data line or reference mark
15	\DATA	DIO/DI	Inverted data line, or reference mark, inverted
-	Shield	-	Shield

<sup>1)</sup> NC = Not connected

### Pin order with Tamagawa absolute encoders

Pin	Name	Direction	Description
1	SIN-	AI	Sine ref.
2	COS-	AI	Cosine ref.
3	PTC/Pt1000/KTY	AI	Temperature sensor
4	PTC/Pt1000/KTY_0V	AI	Common, 0V, reserved for temperature sensor
5	CLOCK	DO/AI	Clock or sine commutation signal
6	SIN+	AI	Sine signal
7	COS+	AI	Cosine signal
8	COM_B	-	Common, 0V
9	NC <sup>1)</sup>	AI	Cosine commutation signal

## 24 Installation

10	\CLOCK	DO/AI	Inverted clock or sine commutation signal, inverted
11	VCC_ENC_2	PO	Supply voltage (5.5 V or 8 V)
12	COM_B	-	Common, 0V
13	NC <sup>1)</sup>	AI	Cosine commutation signal, inverted
14	DATA	DIO/DI	Data line or reference mark
15	\DATA	DIO/DI	Inverted data line, or reference mark, inverted
-	Shield	-	Shield

<sup>1)</sup> NC = Not connected

### ■ TTL encoder emulation output (X43)

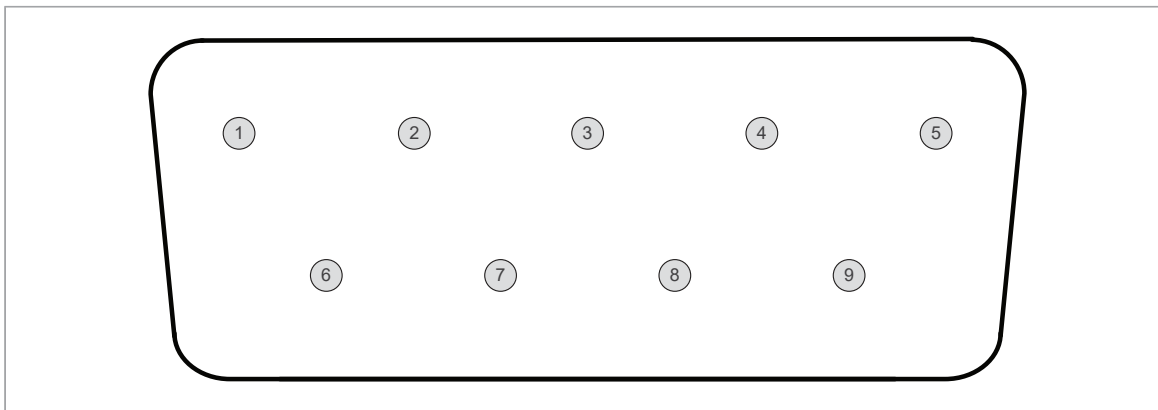

Pin	Name	Direction	Description
1	EM_A+	DO	Channel A+
2	EM_B+	DO	Channel B+
3	EM_Z+	DO	Channel Z+
4	COM_B	-	Common
5	COM_B	-	Common
6	EM_A-	DO	Channel A-
7	EM_B-	DO	Channel B-
8	EM_Z-	DO	Channel Z-
9	COM_B	-	Common
-	Shield	-	Shield



## ■ Digital inputs for position latching (X44)

Pin	Name	Direction	Description
1	+24V_C	PO	Supply voltage
2	COM_C	-	Common
3	DI_1+	DI	Latch signal 1
4	DI_1-	-	Latch signal 1 return
5	DI_2+	DI	Latch signal 2
6	DI_2-	-	Latch signal 2 return

## General encoder wiring guidelines

The encoders should be connected to the encoder interface module with a shielded instrumentation cable, preferably with twisted pairs. See the encoder manual for additional requirements. To prevent the encoder inputs from being disturbed, the cable shield must be connected to the chassis. The connection is made automatically through the metal hood of the plug, if the cables are connected through the cable clamp of the plug.

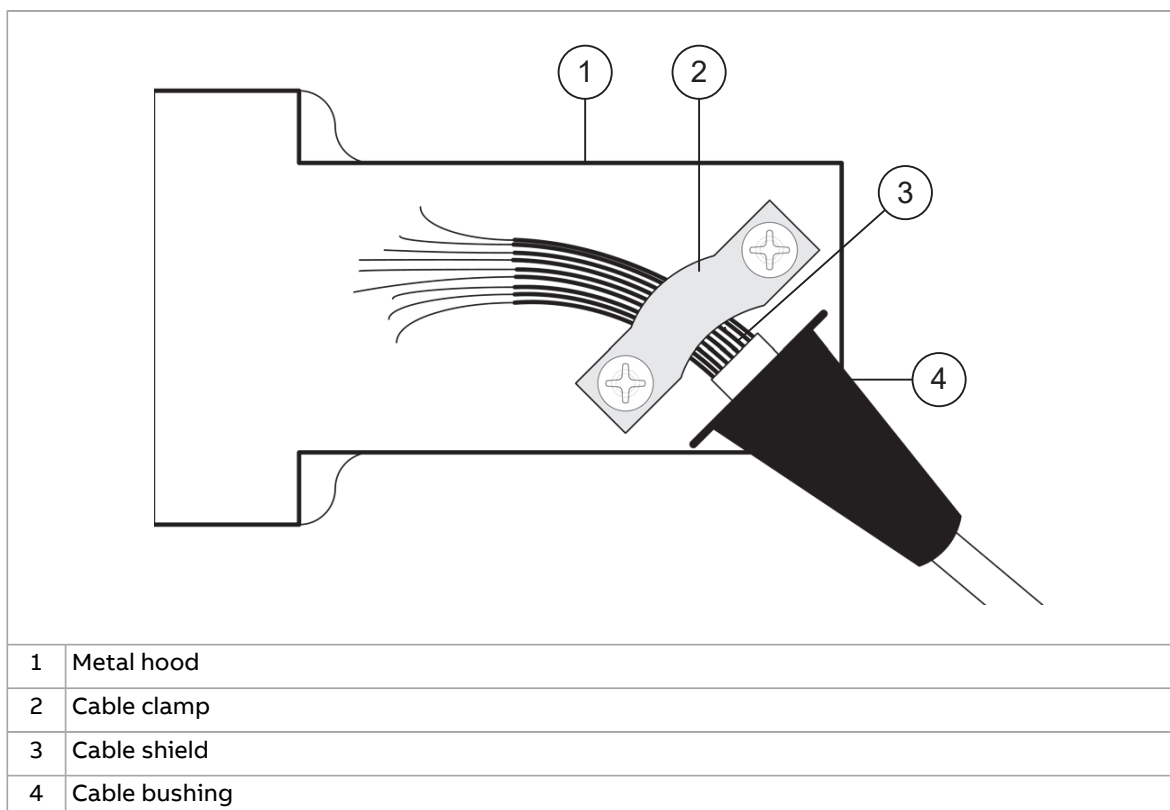

**Note:** Do not route the encoder cables parallel to power (e.g. motor) cables.

Tightening torque is 0.3 Nm (2.7 lbf-in.) for the plugs.

The allocation of cable pairs is described for each connector in the following sections.

■ **TTL encoder input (X41)**

The cable should have minimum 4 cable pairs. A fifth cable pair shared between Vcc and 0V pins allows for a longer cable.

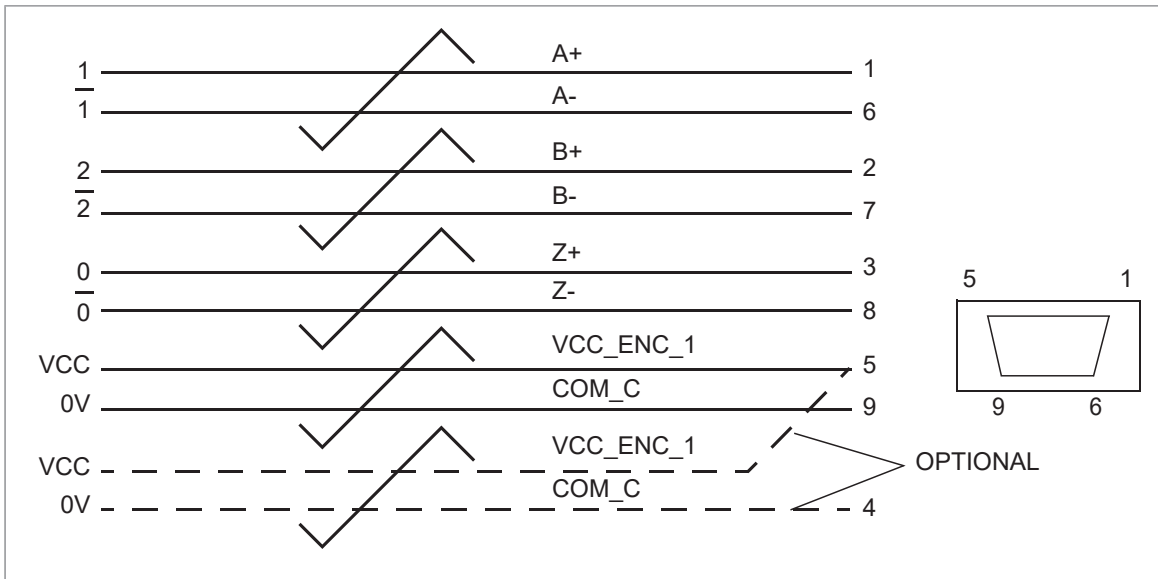

Cable pair number	Signals name	Connecting plug pin number (9-pins)	Notes
1	A+	1	
	A-	6	
2	B+	2	
	B-	7	
3	Z+	3	
	Z-	8	
4	VCC_ENC_1	5	
	COM_C	9	
5	VCC_ENC_1 <sup>1)</sup>	5 <sup>1)</sup>	OPTIONAL
	COM_C	4	OPTIONAL

<sup>1)</sup> Two wires soldered to the same pin.

■ **Absolute encoder input (X42)**

The cable should have minimum 7 cable pairs. An extra pair shared between Vcc and 0V pins allows for a longer cable. Includes an integrated 120 ohm termination resistor.

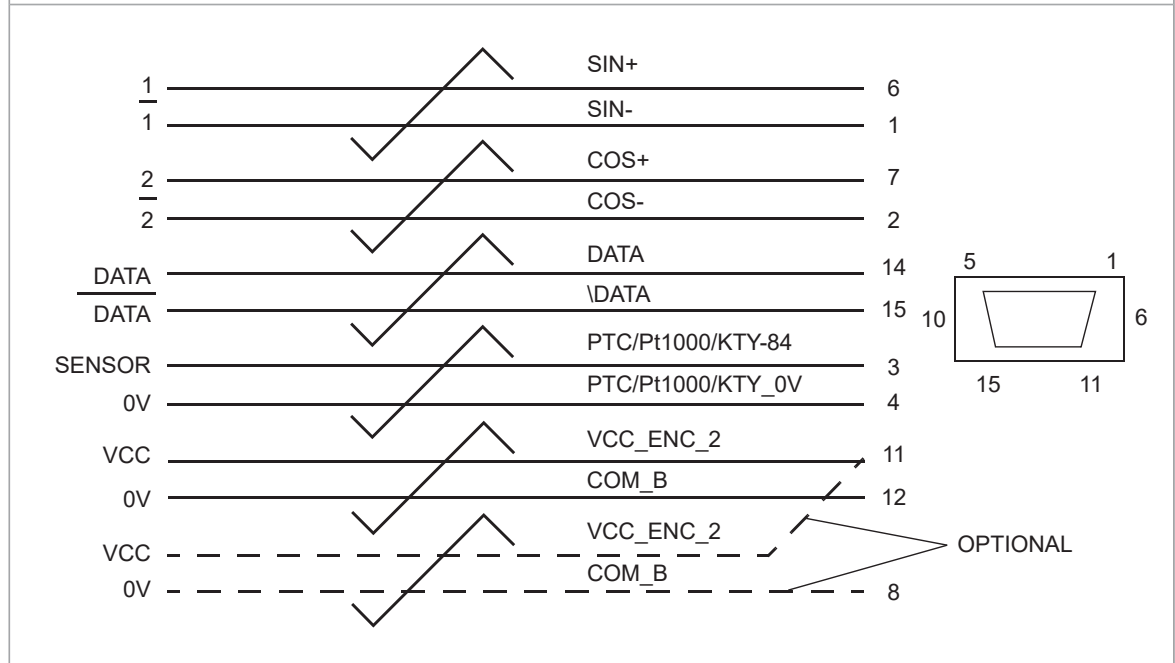
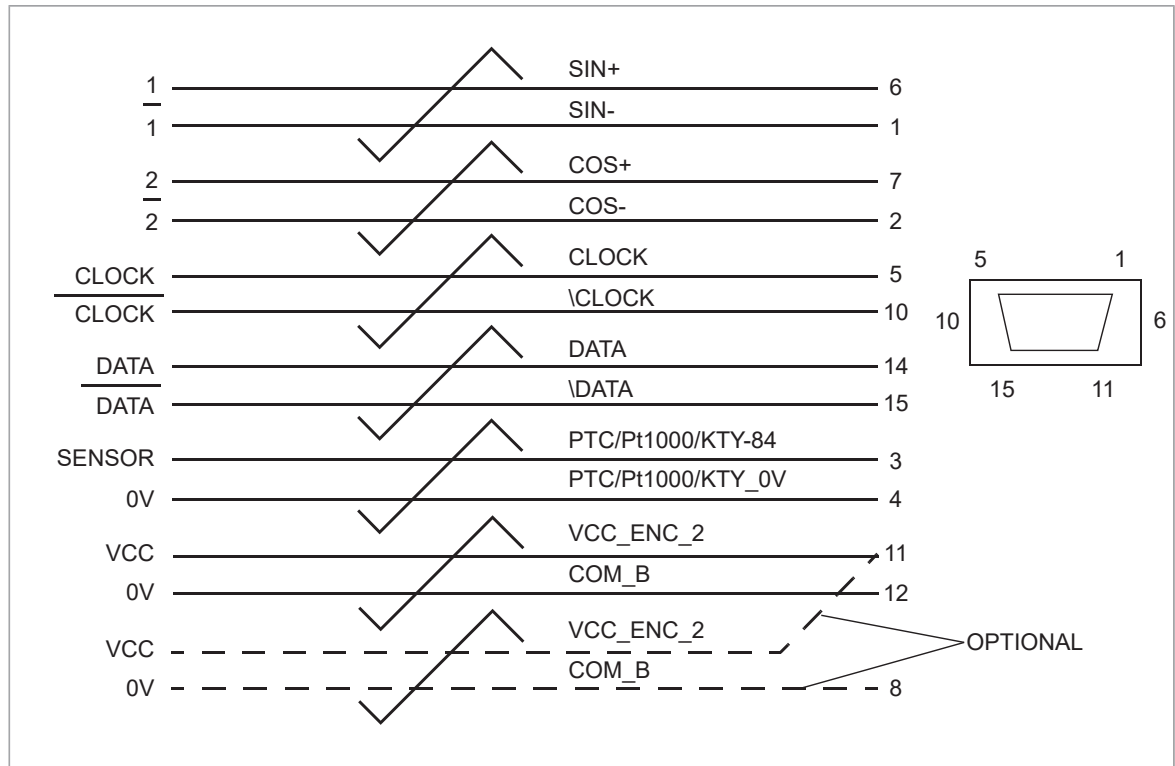

28 Installation

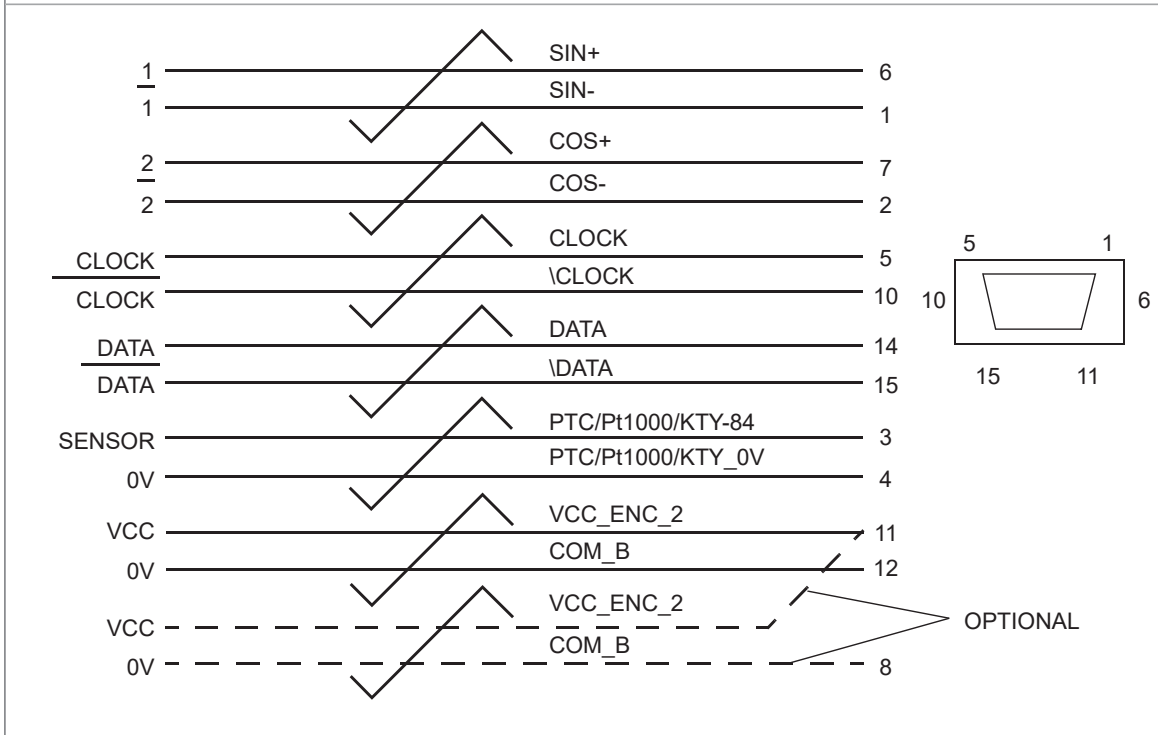
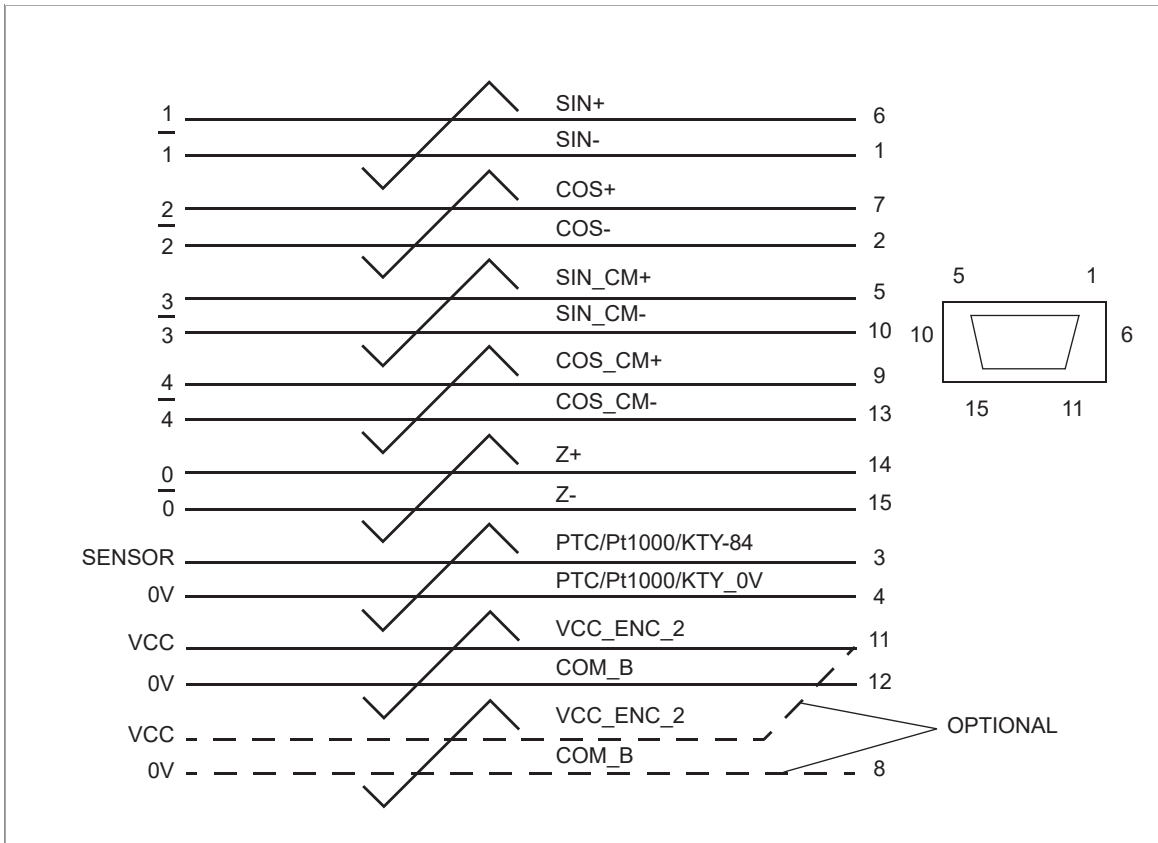

Cable pair number	Signals name	Connecting plug pin number (15-pins)	Notes
1	SIN+	6	
	SIN-	1	
2	COS+	7	
	COS-	2	

3	CLOCK	SIN_CM+	5	
	\CLOCK	SIN_CM-	10	
4	-	COS_CM+	9	
	-	COS_CM-	13	
5	DATA	Z+	14	
	\DATA	Z-	15	
6	PTC/Pt1000/KTY-84		3	Temperature sensor
	COM_B		4	Temperature sensor
7	VCC_ENC_2		11	
	COM_B		12	
8	VCC_ENC_2 <sup>1)</sup>		11 <sup>1)</sup>	OPTIONAL
	COM_B		8	OPTIONAL

1) Two wires soldered to the same pin.



**WARNING!**

You can connect a motor temperature sensor to the encoder module only if there is double or reinforced insulation between the live parts of the motor and the sensor. The module does not provide a safe isolation from the drive. Refer to the drive manuals for more information.

■ **TTL encoder emulation output (X43)**

The cable should have 4 cable pairs.

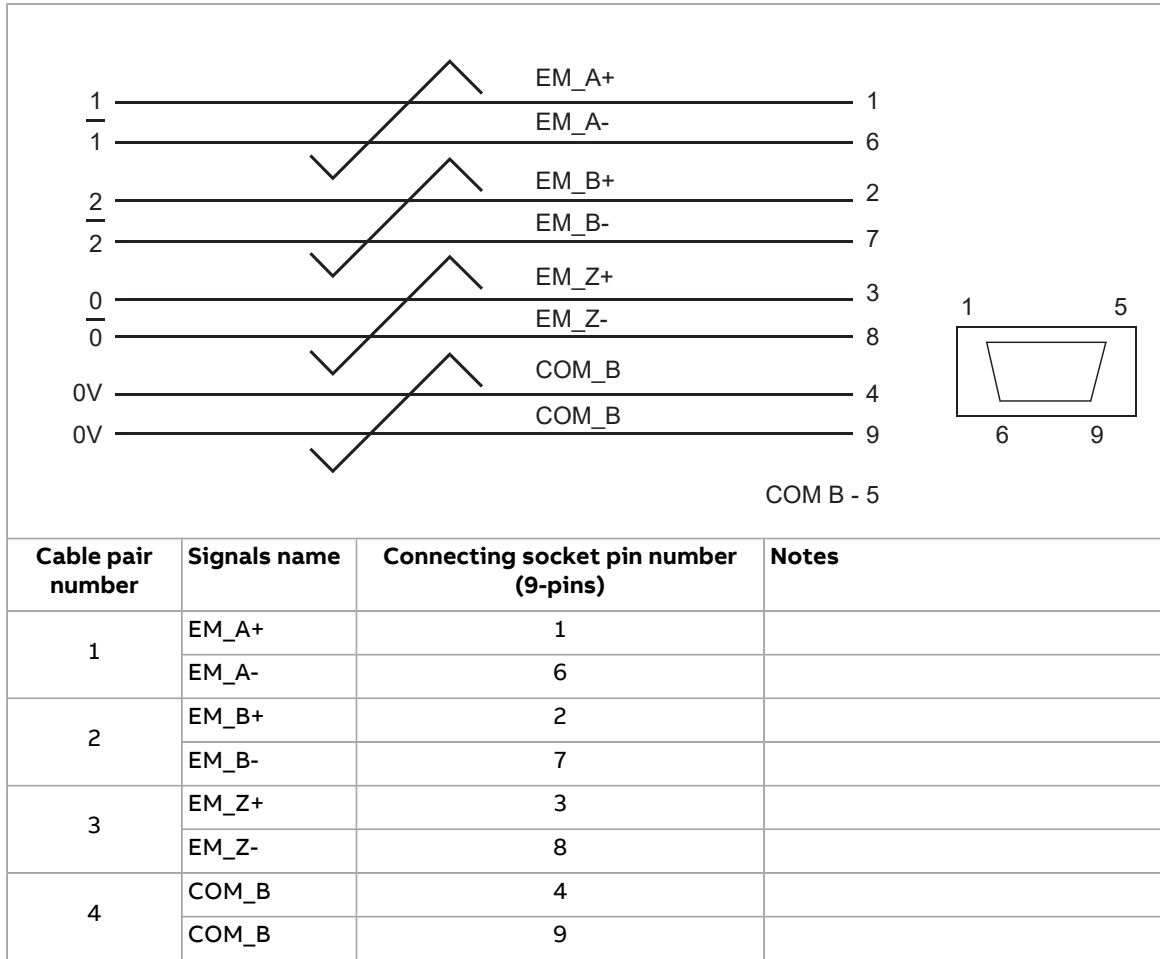

■ **Digital inputs for position latching (X44)**

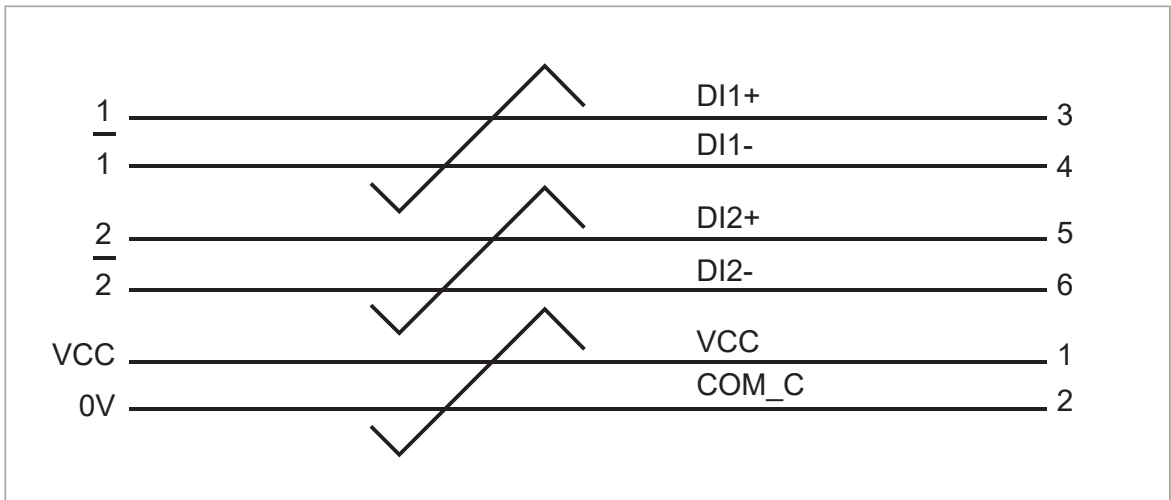

Cable pair number	Signals name	Connecting header pin number (6-pins)	Notes
1	+24V_C	1	
	COM_C	2	
2	DI_1+	3	
	DI_1-	4	
3	DI_2+	5	
	DI_2-	6	

**General encoder phasing principle**

When the encoder is connected correctly, running the drive in the Forward (positive speed reference) direction should produce a positive encoder feedback.

On incremental encoders, the two output channels, usually marked 1 and 2 or A and B, are 90° (electrical) apart from each other. When rotated clockwise, most encoders have channel 1 leading channel 2 as illustrated below. Determine the leading channel by referring to the encoder documentation or by measuring with an oscilloscope.

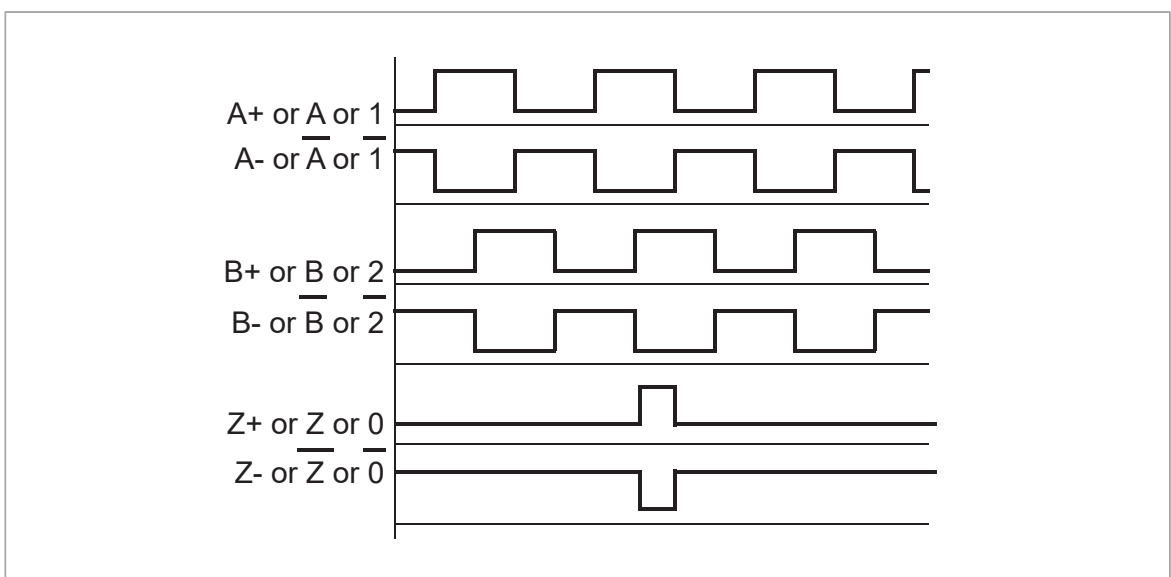

The encoder output channel that leads when the drive runs Forward should be connected to FEN-11 input A, the output channel that trails to FEN-11 input B.

The zero reference output channel (usually marked 0, N or Z) needs to be connected in positioning applications only.

■ **EnDat and SSI serial link**

The figures below show the incremental signals of each supported sine/cosine encoder type when the drive runs forward.

**EnDat/SSI/incremental encoders:** The output channel that leads when the drive runs forward should be connected to FEN- 11 input COS, the output channel that trails to FEN-11 input SIN. See also the note below.

**Note:** Incremental signals used with EnDat serial link, used with SSI serial link and when serial link is not configured.

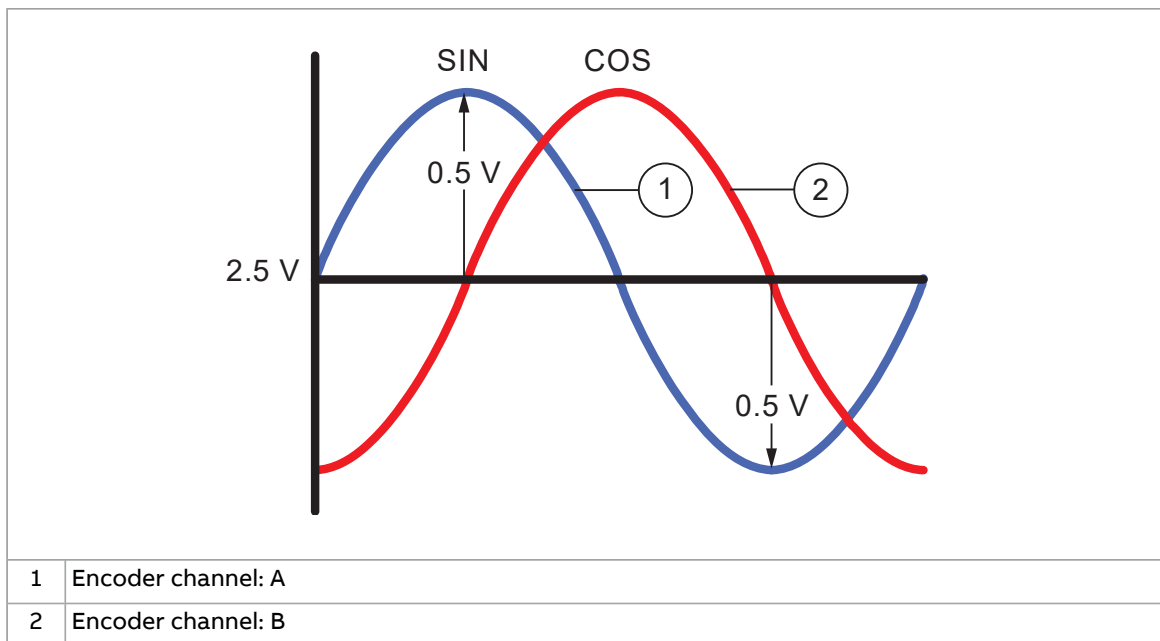



## ■ HIPERFACE serial link

**HIPERFACE encoders:** The output channel that leads when the drive runs forward should be connected to FEN-11 input SIN, the output channel that trails to FEN-11 input COS.

**Note:** If an SSI encoder provides incremental signals that correspond to SIN and COS provided by HIPERFACE encoders (shown in the figure below), the cosine channel should be inverted in order to meet the requirement for incremental signals used with SSI serial link (shown in the figure above).

Incremental signals used with HIPERFACE serial link

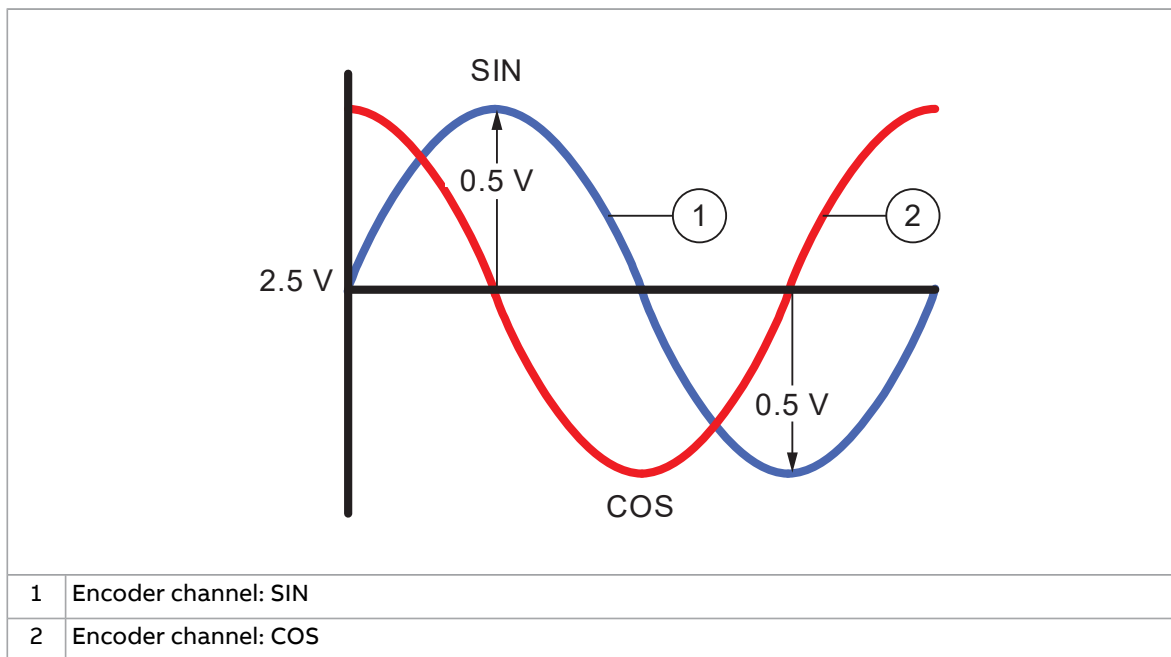

■ **Encoder commutation signals**

Encoder commutation signals (one sine/cosine period per revolution) should be connected to FEN-11 inputs SIN\_CM and COS\_CM according to the figure below (if such signals are available).

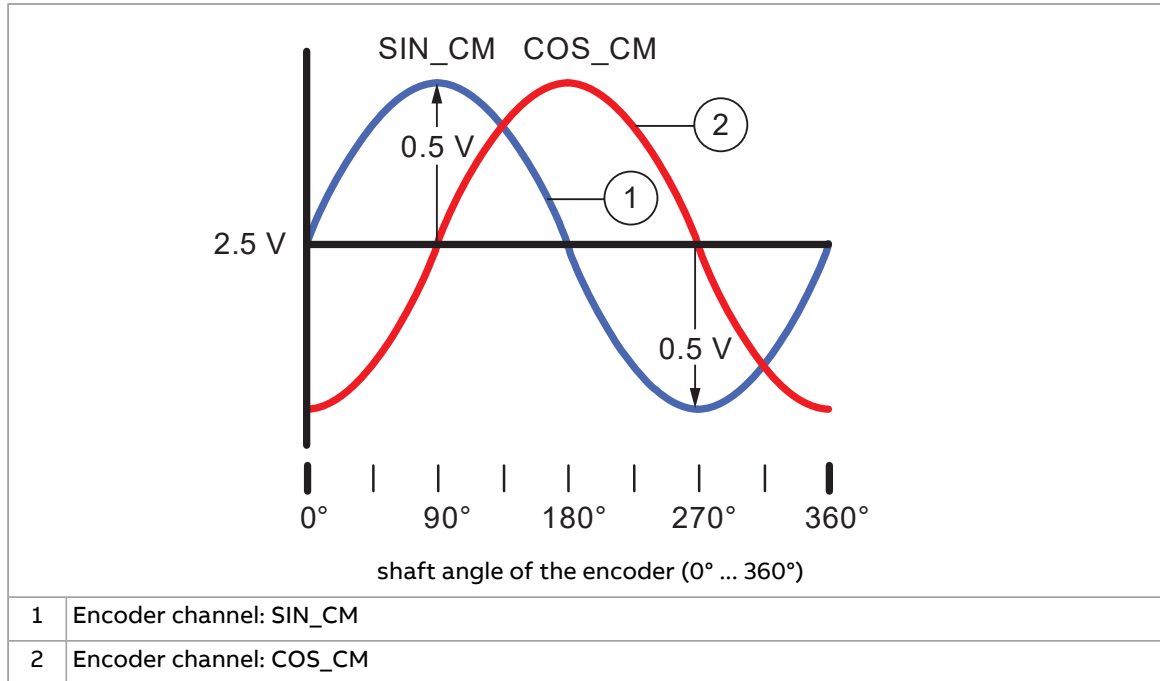

**Reference mark**

The zero reference output channel (usually marked 0, N or Z) needs to be connected in positioning applications only.

5

## Start-up

---

### Contents of this chapter

This chapter contains instructions on starting up the Encoder Interface module.

### Programming

The FEN-11 is programmed through drive parameters. These parameters must be checked and adjusted according to the encoder data sheet. For further information, see the drive Firmware Manual.

---





## Fault tracing

---

### Contents of this chapter

This chapter shows how to trace faults with the status LEDs on the Absolute Encoder Interface module.

### Diagnostic LEDs

The FEN-11 is equipped with two diagnostic LEDs. The STATUS LED describes the status of the FEN-11 and the ENC ST LED the status of the encoders. Description of the LED signals is presented below.

	Colour	Description
<b>STATUS LED</b>	Green	OK
	Orange	Not initialized or communication fault to the drive
	Red	Not in use
<b>ENC ST LED</b>	Green	Encoder(s) OK
	Red	TTL encoder (X41) fault
	Orange	Absolute encoder (X42) fault
	Red/orange swapping	TTL encoder fault X41 and absolute encoder X42 fault
	Red flashing	TTL encoder (X41) warning
	Orange flashing	Absolute encoder (X42) warning
	OFF	Incorrect encoder parameter configuration. <b>Note:</b> This concerns FEN-11 usage with ACS880.

**Note:** When using FEN-11 with ACS880 the status of ENC ST LED is updated after encoder fault reset is done.

---





# 7

## Technical data

---

### Contents of this chapter

This chapter contains the technical data of the Absolute Encoder Interface module.

---

## Dimensions

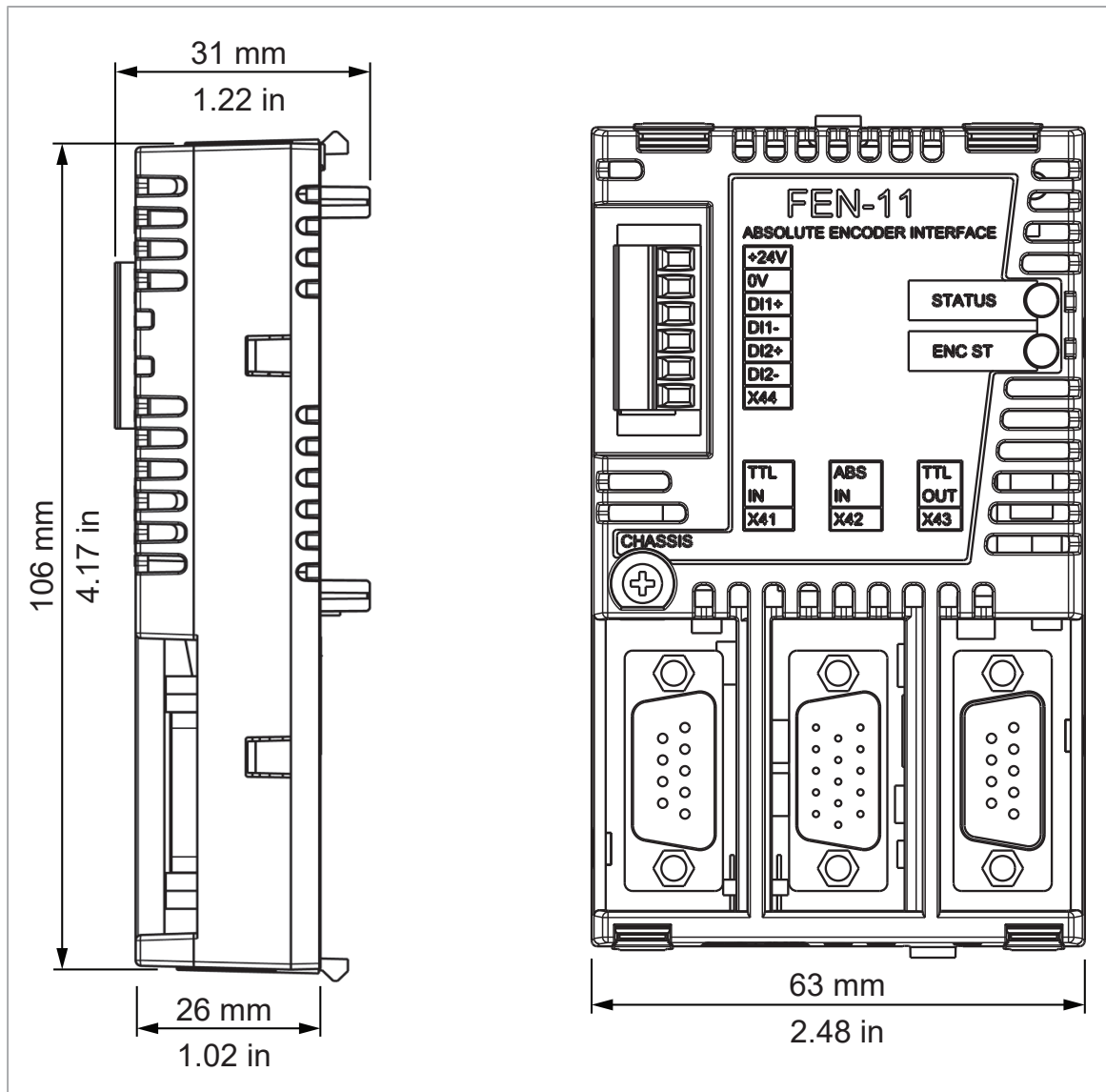

## General

Max. power consumption	350 mA at 24 V (Max. combined power consumption of encoders, latches and cabling 5W)
Degree of protection	IP20
Ambient conditions	The applicable ambient conditions specified for the drive in its Hardware Manual are in effect.



## Connectors:

- 20-pin socket
- 9-pin D-sub socket
- 15-pin D-sub socket
- 9-pin D-sub plug
- 6-pin header.

## TTL encoder input (X41)

Output voltages	+5.5 V DC -5%, -8%, 180 mA
	+24 V DC ±15%, 150 mA together with digital inputs
	+5.5 V and +24 V combined maximum power is 3.6 W
CH A, CH B, CH Z	RS-422/485, differential, 500 kHz (max)
Maximum cable length	30 m with a 5 V encoder (0.5 mm <sup>2</sup> cable for power supply)
	60 m with a 5 V encoder (two parallel 0.5 mm <sup>2</sup> cables for power supply)
	100 m with a 10...30 V TTL incremental encoder
Performance	Speed range: -32768...32767 rpm
	Speed resolution: 0.004 rpm (24 bits)
	Position resolution: 16.8 M/rev (24 bits)
	Position accuracy: 4x pulse count/rev
Isolation	Isolated together with digital inputs

## Absolute encoder input (X42)

Output voltages	+5.5 V DC +1%, -2.5%, 250 mA
	+8 V DC +20%, -5%, 130 mA
Thermistor	KTY84, PT1000 or PTC thermistor input
Sin/cos signals	1 Vp-p (nom), 1.2 Vp-p (max), 500 kHz (max)
Serial link	Signals according to RS-422/485
Maximum cable length	25 m (0.5 mm <sup>2</sup> cable for power supply)
	50 m (two parallel 0.5 mm <sup>2</sup> cables for power supply)
	75 m with an external power source for the encoder
Performance	Speed range: -32768...32767 rpm
	Speed resolution: 0.004 rpm (24 bits)
	Position resolution: 16.8 M/rev (24 bits)
Isolation	Isolated together with TTL encoder emulation output

## TTL encoder emulation output (X43)

Emulation	Supports emulations of TTL incremental encoder, 1...65535 pulses/rev, reference mark
CH A, CH B, CH Z	RS-422/485, 500 kHz (max)
Maximum cable length	100 m
Performance	Speed range: -32768...32767 rpm
	Position resolution: 4x pulse count/rev
Isolation	Isolated together with encoder input

## Digital inputs for position latch (X44)

Output voltage	+24 V DC $\pm$ 15%, short-circuit proof
Signal levels	< 5 V = 0, > 15 V = 1
Isolation	Isolated together with TTL encoder input

---

---

# Further information

## Product and service inquiries

Address any inquiries about the product to your local ABB representative, quoting the type designation and serial number of the unit in question. A listing of ABB sales, support and service contacts can be found by navigating to [www.abb.com/searchchannels](http://www.abb.com/searchchannels).

## Product training

For information on ABB product training, navigate to [new.abb.com/service/training](http://new.abb.com/service/training).

## Providing feedback on ABB manuals

Your comments on our manuals are welcome. Navigate to [new.abb.com/drives/manuals-feedback-form](http://new.abb.com/drives/manuals-feedback-form).

## Document library on the Internet

You can find manuals and other product documents in PDF format on the Internet at [www.abb.com/drives/documents](http://www.abb.com/drives/documents).



[www.abb.com/drives](http://www.abb.com/drives)



3AFE68784841D